



REGISTER YOUR PRODUCT ONLINE

at championpowerequipment.co.uk



TAKEYOURGENERATOROUTSIDE.COM

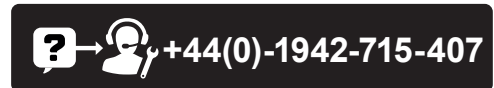

+44(0)-1942-715-407

or visit www.championpowerequipment.co.uk

SAVE THESE INSTRUCTIONS. This manual contains important safety precautions which should be read and understood before operating the product. Failure to do so could result in serious injury. This manual should remain with the product.

Specifications, descriptions and illustrations in this manual are as accurate as known at the time of publication, but are subject to change without notice.

**TAKE IT
OUTSIDE™**



CARBON MONOXIDE KILLS

CARBON MONOXIDE SAFETY: THE BIG PICTURE

As the only safe way to use a portable generator, taking your generator outside is absolutely mandatory to keep your family safe from carbon monoxide. But there's even more you can do. By educating yourself about all carbon monoxide risks, you'll be better prepared to protect your family from this colorless, odorless threat.



**ALWAYS READ
THE OPERATOR'S
MANUAL FIRST**



KNOW THE SYMPTOMS

- Headache
- Nausea
- Shortness of breath
- Dizziness
- Fatigue

**STAY ALERT WITH CARBON
MONOXIDE DETECTORS**

**KEEP IT OUTSIDE AND AWAY FROM
DOORS, WINDOWS, AND GARAGES**

**IF YOU FEEL SYMPTOMS,
LEAVE RIGHT AWAY**

**POINT FUMES AWAY FROM
NEARBY PEOPLE**

www.TakeYourGeneratorOutside.com

TABLE OF CONTENTS

Introduction	4	Cable Storage	10
Safety Definitions	4	Specifications	11
Important Safety Instructions	5	Specifications	11
Safety Symbols	7	Parts Diagram	12
Controls and Features	8	Parts List	13
Control Panel	8	Wiring Diagram	14
Assembly and Operation	9		
Paralleling Two Inverters	9		
Adjusting the Anti-Vibration Wedges	10		

INTRODUCTION

Congratulations on your purchase of a Champion Power Equipment (CPE) product. CPE designs, builds, and supports all of our products to strict specifications and guidelines. With proper product knowledge, safe use, and regular maintenance, this product should bring years of satisfying service.

Every effort has been made to ensure the accuracy and completeness of the information in this manual at the time of publication, and we reserve the right to change, alter and/or improve the product and this document at any time without prior notice.

CPE highly values how our products are designed, manufactured, operated, and serviced as well as providing safety to the operator and those around the generator. Therefore, it is **IMPORTANT** to review this product manual and other product materials thoroughly and be fully aware and knowledgeable of the assembly, operation, dangers and maintenance of the product before use. Fully familiarize yourself, and make sure others who plan on operating the product fully familiarize themselves too, with the proper safety and operation procedures before each use. Please always exercise common sense and always err on the side of caution when operating the product to ensure no accident, property damage, or injury occurs. We want you to continue to use and be satisfied with your CPE product for years to come.

When contacting CPE about parts and/or service, you will need to supply the complete model and serial numbers of your product. Transcribe the information found on your product's nameplate label to the table below

CPE TECHNICAL SUPPORT TEAM
+44(0)-1942-715-407
MODEL NUMBER
500740-WL-UK
SERIAL NUMBER
DATE OF PURCHASE
PURCHASE LOCATION

SAFETY DEFINITIONS

The purpose of safety symbols is to attract your attention to possible dangers. The safety symbols, and their explanations, deserve your careful attention and understanding. The safety warnings do not by themselves eliminate any danger. The instructions or warnings they give are not substitutes for proper accident prevention measures.

DANGER

DANGER indicates a hazardous situation which, if not avoided, will result in death or serious injury.

WARNING

WARNING indicates a hazardous situation which, if not avoided, could result in death or serious injury.

CAUTION

CAUTION indicates a hazardous situation which, if not avoided, could result in minor or moderate injury.

NOTICE

NOTICE indicates information considered important, but not hazard-related (e.g., messages relating to property damage).

IMPORTANT SAFETY INSTRUCTIONS

⚠ DANGER

Generator exhaust contains carbon monoxide, a colorless, odorless, poisonous gas. Breathing carbon monoxide will cause nausea, dizziness, fainting or death. If you start to feel dizzy or weak, get to fresh air immediately.

OPERATE GENERATOR OUTDOORS ONLY IN A WELL VENTILATED AREA AND POINT EXHAUST AWAY.

DO NOT operate the generator inside any building, including garages, basements, crawlspaces and sheds, enclosure or compartment, including the generator compartment of a recreational vehicle.

DO NOT allow exhaust fumes to enter a confined area through windows, doors, vents or other openings.

⚠ DANGER

Using a generator indoors **CAN KILL YOU IN MINUTES**. Generator exhaust contains carbon monoxide. This is a poison you cannot see or smell.

NEVER use inside a home or garage, **EVEN IF** doors and windows are open.

ONLY use **OUTSIDE** and far away from windows, doors, and vents.

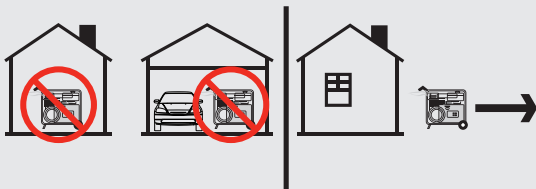

Install battery-operated carbon monoxide alarms or plug-in carbon monoxide alarms with battery back-up according to the manufacturer's instructions.

⚠ WARNING

Although the generator contains a spark arrester, maintain a minimum distance of 5 ft. (1.5 m) from dry vegetation to prevent fires.

⚠ DANGER

Operate equipment with guards in place.

Rotating parts can entangle hands, feet, hair, clothing and/or accessories. Traumatic amputation or severe laceration can result.

Keep hands and feet away from rotating parts.

Tie up long hair and remove jewelry.

DO NOT wear loose-fitting clothing, dangling drawstrings or items that could become caught.

⚠ DANGER

Generator produces powerful voltage.

DO NOT touch bare wires or receptacles.

DO NOT use electrical cords that are worn, damaged or frayed. Use only Champion electrical cords for proper application.

DO NOT operate generator in wet weather.

DO NOT allow children or unqualified persons to operate or service the generator.

Use a ground fault circuit interrupter (GFCI) in damp areas and areas containing conductive material such as metal decking.

Connection to your home's electrical system requires a listed 30A transfer switch installed by a licensed electrician and approved by the local authority having jurisdiction. The connection must isolate the generator from the utility power and must comply with all applicable laws and electrical codes.

⚠ WARNING

Do not use generator for medical and life support uses.

In case of emergency, call 911 immediately.

NEVER use this product to power life support devices or life support appliances.

NEVER use this product to power medical devices or medical appliances.

Inform your electricity provider immediately if you or anyone in your household depends on electrical equipment to live.

Inform your electrical provider immediately if a loss of power would cause you or anyone in your household to experience a medical emergency.

⚠ WARNING

Spark from removed spark plug wire can result in fire or electrical shock.

When servicing the generator:

Disconnect the spark plug wire and place it where it cannot contact the plug or any other metal object.

DO NOT check for spark with the plug removed.

Use only approved spark plug testers.

⚠ WARNING

Running engines produce heat. Severe burns can occur on contact. Combustible material can catch fire on contact.

DO NOT touch hot surfaces.

Avoid contact with hot exhaust gases.

Allow equipment to cool before touching.

Maintain at least 3 ft. (91.4 cm) of clearance on all sides to ensure adequate cooling.

Maintain at least 5 ft. (1.5 m) of clearance from combustible materials.

⚠ WARNING

Rapid retraction of the recoil cord will pull hand and arm towards the engine faster than you can let go. Broken bones, fractures, bruises or sprains could result. Unintentional startup can result in entanglement, traumatic amputation or laceration.

When starting engine, pull the recoil cord slowly until resistance is felt and then pull rapidly to avoid kickback.

DO NOT start or stop the engine with electrical devices plugged in and turned on.

⚠ CAUTION

Exceeding the generator's running capacity can damage the generator and/or electrical devices connected to it.







DO NOT overload the generator.

DO NOT tamper with the governed speed.

DO NOT modify the generator in any way.

Safety Symbols

Some of the following symbols may be used on this product. Please study them and learn their meaning. Proper interpretation of these symbols will allow you to more safely operate the product.

SYMBOL	MEANING
	<p>Read Operator's Manual. To reduce the risk of injury, user must read and understand operator's manual before using this product.</p>
	<p>Electric Shock. Failure to use in dry conditions and to observe safe practices can result in electric shock. Improper connections to a building can allow current to backfeed into utility lines, creating an electrocution hazard. A transfer switch must be used when connecting to a building.</p>
	<p>Fire/Explosion. Fuel and its vapors are extremely flammable and explosive. Fire or explosion can cause severe burns or death. Keep generator at least 5 feet (1.5m) from all objects to prevent combustion.</p>
	<p>Hot Surface. To reduce the risk of injury or damage, avoid contact with any hot surface.</p>
	<p>Open Flame Alert. Fuel and its vapors are extremely flammable and explosive. Keep fuel away from smoking, open flames, sparks, pilot lights, heat, and other ignition sources.</p>
	<p>Wet Conditions Alert. Do not expose to rain or use in damp locations.</p>

CONTROLS AND FEATURES

Read this operator's manual before operating your Parallel Kit. Familiarize yourself with the location and function of the controls and features. Save this manual for future reference.

Control Panel

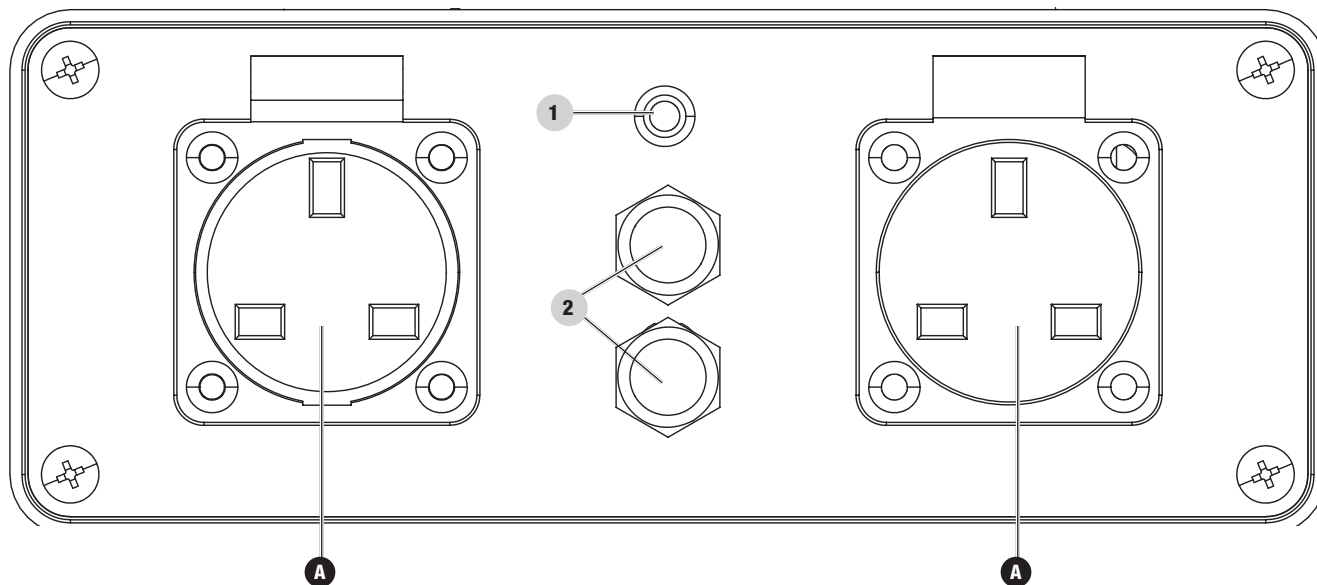

1. **Power Indicator** – Illuminates green when power is being supplied to the parallel kit.
2. **Circuit Breakers (Push Reset)** – Protects the generator against electrical overloads.

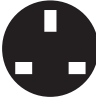
RECEPTACLES	
A	 <p>2 x 240V AC, 13A May be used to supply electrical power for operation of 240 Volt AC, 13 Amp, single phase, 50 Hz electrical loads.</p>

ASSEMBLY AND OPERATION

This parallel kit is intended for use with Champion Power Equipment inverters rated between 2000 and 3000 starting watts. Please refer to your inverter Operator's Manuals for safety rules, start up and shut down procedures, specifications, and troubleshooting.

The total output of this kit will depend on the rated wattage of the inverters connected to it. The maximum output of the parallel kit is the amperage rating of the circuit breakers.

Paralleling Two Inverters

⚠ WARNING

If not spaced apart, the exhaust heat from one unit may discolor or melt the plastic on the other unit. Always read your inverter Operator's Manuals before operating the inverters and parallel kit.

1. Ensure both inverters are turned off and all electrical loads are disconnected before installing parallel kit.
2. Align the inverters in a "V" configuration so the exhausts of each inverter are pointed well away from each other and the inverters are a minimum of 18 in. (46 cm) apart.

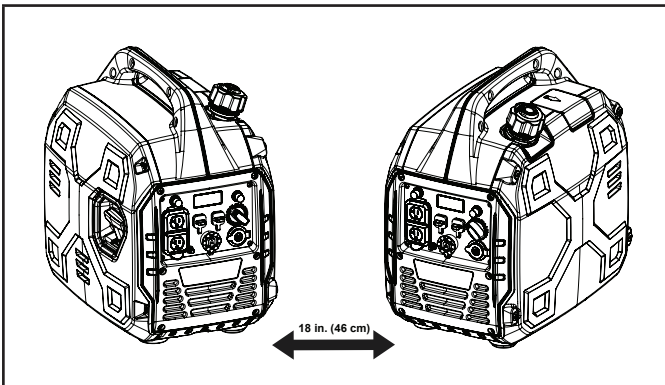

3. Mount the parallel kit to the inverter on the right of the "V" so that it rests on the side without the fuel cap.

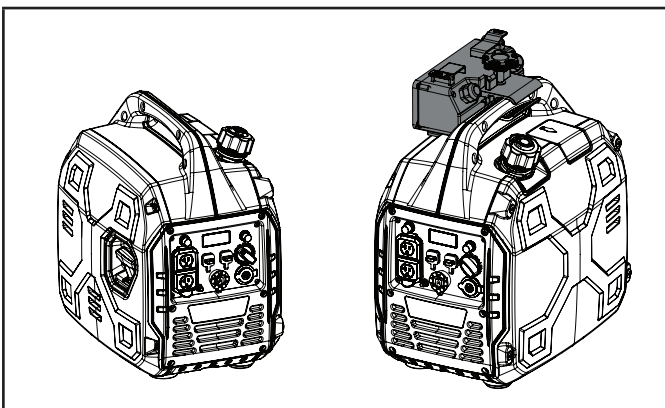

4. Place the bracket around the handle and tighten the fastening dial by turning clockwise until snug. Do not over tighten. You may need to loosen the fastening dial to get it around the handle before tightening.

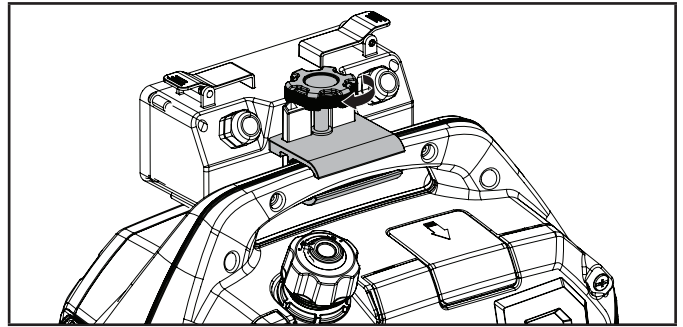

5. On each inverter, lift the parallel port covers, if applicable, and insert the RED power lead into the RED receptacle and the BLACK power lead into the BLACK receptacle.
6. On each inverter, connect the grounding wire to the grounding terminal on the inverter and secure the grounding lugs.
7. Start engine of both inverters according to inverter Operator's Manuals. Observe the green output indicator light on both inverter panels. The light may blink during start up and will turn solid green when loads may be connected.
8. Connect devices to the parallel kit and/or inverters up to the receptacles rated amperage. It is best to connect devices with the largest load first. Allow the engine to stabilize before plugging in more devices. Never exceed the specified capacity of the receptacle.
9. Follow the instructions in the inverter Operator's Manuals when turning off the inverters.

🗨 NOTICE

If the parallel kit has been overloaded and the circuit breaker has been tripped, reduce the load and press the parallel kit reset button to restore power.

🗨 NOTICE

This parallel kit is meant to parallel two ParaLINK compatible inverters together. Both inverters must have ParaLINK parallel receptacles as shown below:

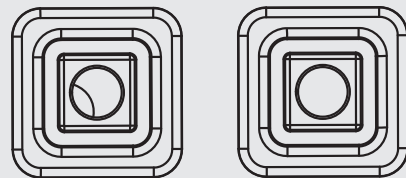

NOTICE

This unit should NOT be used to connect inverters with non-ParaLINK receptacles such as the style shown below:

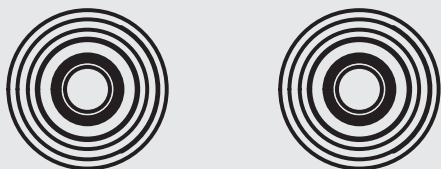
**Adjusting the Anti-Vibration Wedges**

There are two rubber wedges on the bottom of the parallel kit that can be removed or moved to create a friction fit wedge between the parallel kit and inverter. If, after tightening the fastener dial, your parallel kit is vibrating during operation slide the wedges toward the back of the parallel kit until snug to reduce vibration.

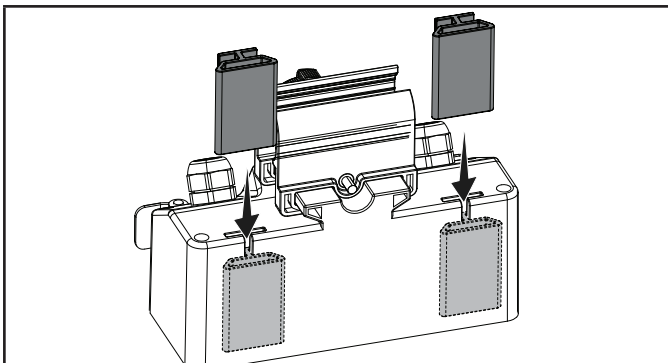
**CABLE STORAGE**

When not in use, neatly wrap the cables and use the spring loaded clips on top of the parallel kit to hold the cables in place.

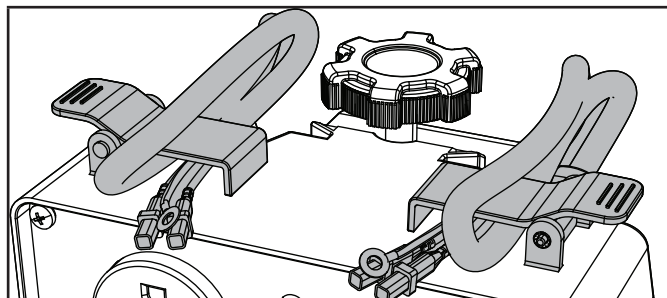

SPECIFICATIONS

Specifications

Model	500740-WL-UK
Volts AC	240
Frequency	50 Hz
Phase	Single
Weight	3.1 lb. (1.39 kg)
Length	8.6 in. (21.8 cm)
Width	6.4 in. (16.2 cm)
Height	5 in. (12.8 cm)

PARTS DIAGRAM

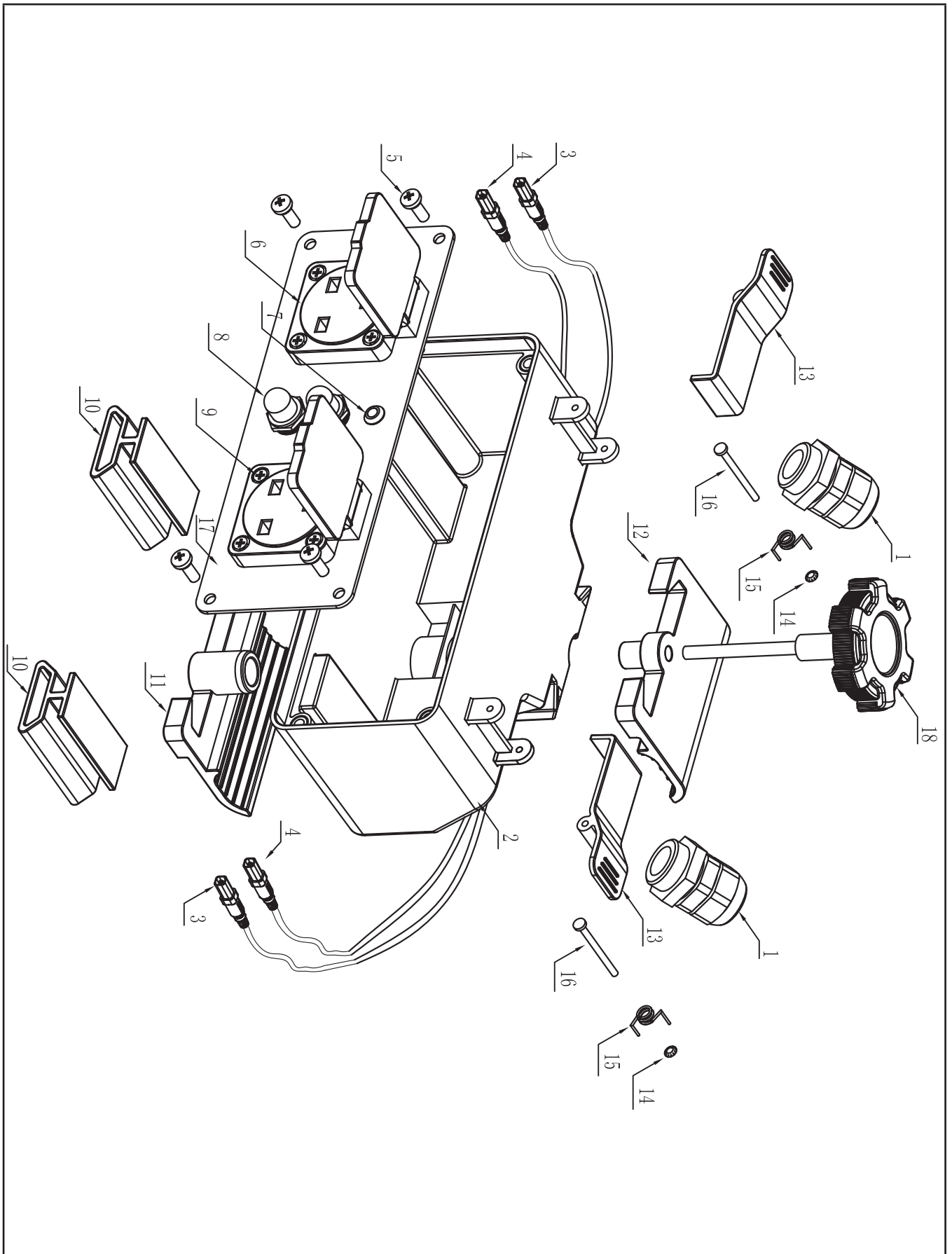

PARTS LIST

#	Part Number	Description	Qty.
1	XIR-C-01	Waterproof Joint, Cable, PG16	2
2	XIR-C-02	Control Box, Flame retardant PP	1
3	XIR-C-03	Parallel Plug, U-158-2, Red	2
4	XIR-C-04	Parallel Plug,U-158-2, Black	2
5	XIR-C-05	Screw/washer assembly, M5 x 16	4
6	XIR-C-06	UK Receptacle, ZNPON Z134E	2
7	XIR-C-07	LED light, Green, 240V	1
8	XIR-C-08	13Amp Circuit Breaker,250V, With M4x8 Screw	2
9	XIR-C-09	Screw M4x15	8
10	XIR-C-10	Rubber Pad	2
11	XIR-C-11	Bottom Clamp, PA6	1
12	XIR-C-12	Upper Clamp, PA6	1
13	XIR-C-13	Wire Clip	2
14	XIR-C-14	Snap Ring M3x9	2
15	XIR-C-15	Spring Φ 1	2
16	XIR-C-16	Pin Shaft, 3 x 40 mm	2
17	XIR-C-17	Control Panel	1
18	XIR-C-18	Knob M6*60MM PA	1

WIRING DIAGRAM

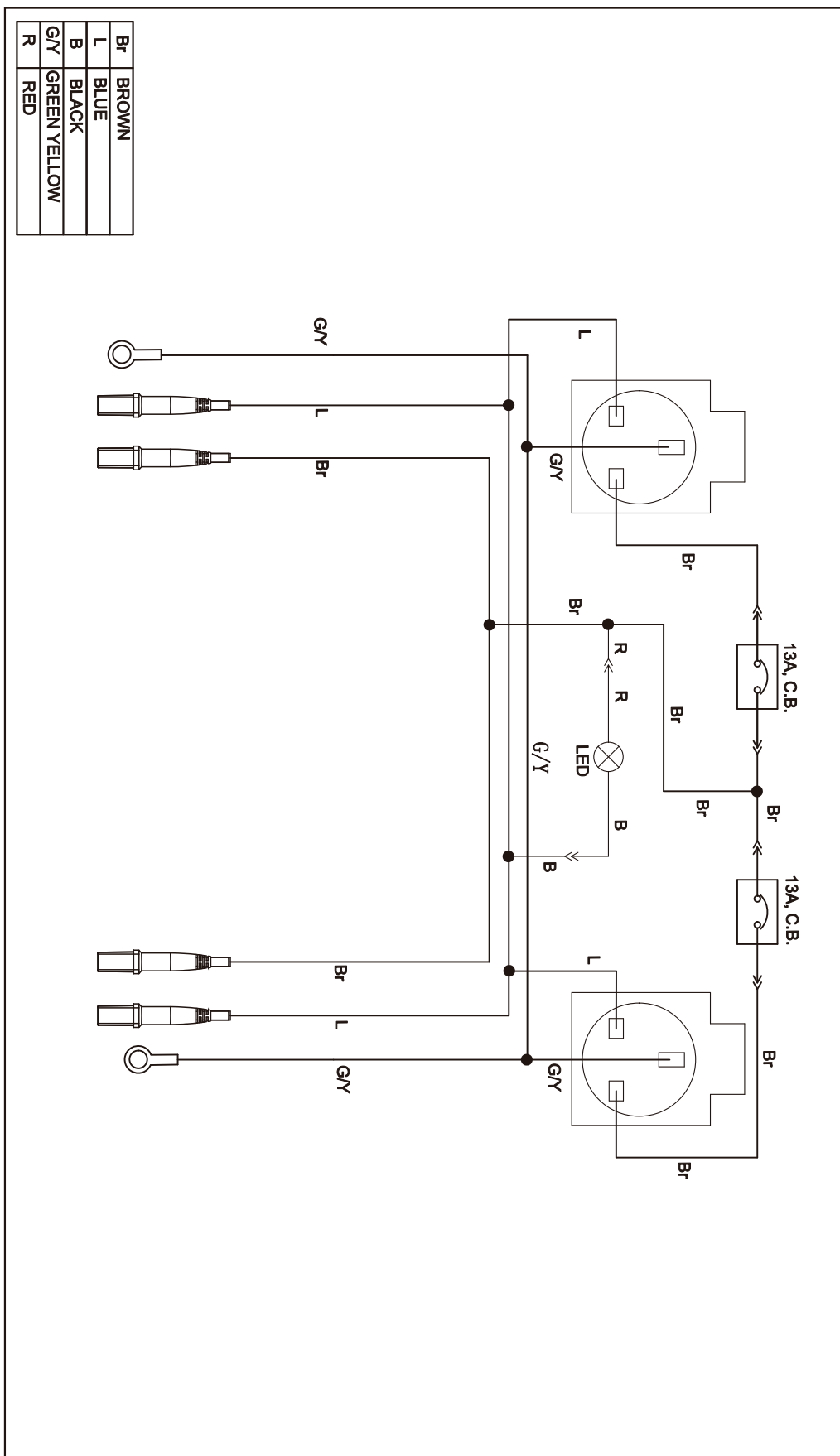

0 0 . 4 0